

**EAT** EuroAudioteam, s.r.o.

# INSTRUCTIONS FOR USE EAT Forte S

Dear Music Lover,

Welcome! Congratulations on your purchase of our EAT Forte S turntable. Your EAT Forte S was hand-crafted by our team of skilled technicians. It has been tested rigorously and is ready for your enjoyment.

Please take the time to read this manual carefully, to ensure that you obtain the ultimate performance from your EAT Forte S turntable. The tips contained within will ensure that your Forte will remain as-new condition for many years to come!

Your EAT Consultant is:

Serial Number:



## EAT Forte

### Controls, features and connections

- 1 Main turntable chassis
  - 2 Platter
  - 3 2x Drive belt
  - 4 Speed control
  - 5 Arm board and Spirit level
  - 6 4 x Adjustable feet
  - 7 Record weight \*
- Grounding cable (not shown) \*
- Power supply (not shown) \*
- Gloves (not shown)\*
- Grease (not shown)\*
- Small tool set (not shown)\*



Warning of a hazard for the user, the unit or possible misuse.

Before starting assembly, please familiarise yourself with the parts listed above. Separately packed items are marked with an asterisk (\*).

## Set-up

For safe and trouble-free installation, we would suggest that you assemble the unit with the assistance of a friend, due to the weight of the complete turntable system.

- 1) Open the shipping crate by unscrewing the top of the crate. Remove the wooden top.
- 2) Remove the styrofoam top layer, with the accessories.
- 3) Unpack the first part of the turntable: the main chassis. Remove the packaging fabric from the main turntable chassis. Install the earthing cable at the bottom of the main chassis. You will find the earthing cable inside the box of accessories.
- 4) Unpack the last part of the turntable: the platter. Remove the plastic transport cover over the bearing shaft. Remove the red transport cap on the bottom of the platter. Please check to ensure there is enough grease on the bearing shaft. If the shaft is too dry, please use the grease that you find in the accessories box. Install the platter carefully. The best method is for one person to hold the platter with a second person locating the platter into the bearing into the correct position.

**IMPORTANT NOTE:** Please check the level of the grease in the bearing shaft every three months, by removing the platter from the bearing.

- 5) Set up the height and the levelling of the chassis by turning the feet to the left side or right. By turning the feet to the right, the chassis will raise; turning the feet to the left will lower the turntable. Finally, level the Forte with the spirit level in the accessories box.
- 6) Install the two white drive belts. There are two different belt lengths. First, please install the shorter belt to the lower positioned motor pulley, the pulley closer to the front of the motor assembly. Second, install the longer belt to the higher motor pulley, at the rear of the motor assembly.
- 7) Attach the power supply to the back of the turntable chassis.
- 8) Switch on the motor unit. The small green light will indicate that power has been switched on.

The speed control has 3 buttons:     - 33

   - STBY - STOP

   - 45

By pressing the 33 button you switch on the motor to 33.3rpm.. Please, wait until the blue light indicator stabilize. If you wish to change speed to 45rpm. press the button on the right side - 45. Please, wait until the blue light stabilize. If you wish to stop the turntable please press the STBY- STOP button.

### Useful tips

The base and the record player should be positioned on a low-resonance surface, such as wood or multiple-layer ply board, to avoid structural vibrations disturbing replay.

### Mains power connection

The turntable is supplied with a power supply suitable for your country's mains supply. Check the label before connecting to ensure compliance with the mains rating in your home.

If the player is not used over a long period of time, the drive belt can be removed to prevent undesired stretching.



As a safety precaution, always disconnect the record player from the mains power supply before maintenance!

### Technical specifications EAT Forte S

|                           |  |
|---------------------------|--|
| * Electronic speed change | * 33.33/* 45.11  |
| Speed variance            | ±0.09%   |
| Wow and flutter           | ±0.01%   |
| Signal-to-noise ratio     | -73dB  |
| Power consumption         | 4W   |
| Outboard power supply     | 16V/1.000mA AC, suitable for your country's mains supply |
| Dimensions (WxHxD)        | 550x250x450mm  |
| Weight                    | 44kg   |

## Pro-Ject 12CC Evolution Tonearm

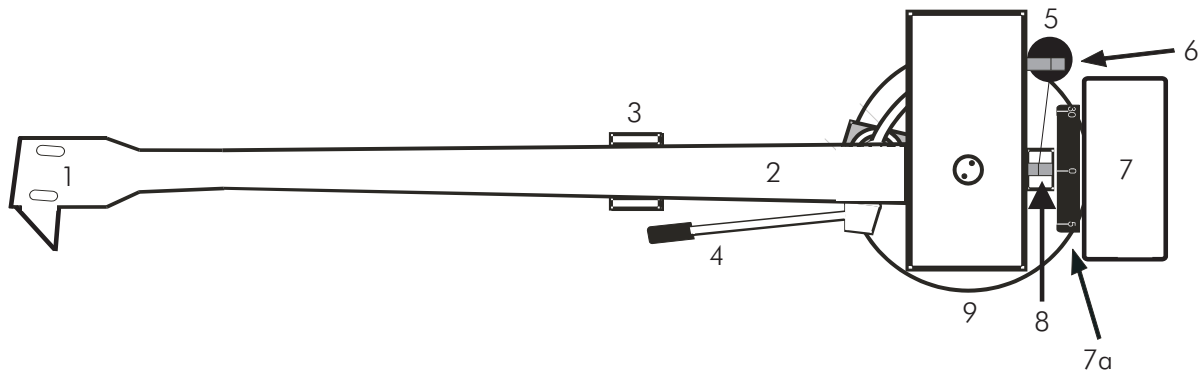

- 1 Headshell with finger lift
- 2 Tonearm tube
- 3 Tonearm rest and removable transport lock
- 4 Tonearm lift lever
- 5 Anti-skating weight \*
- 6 Anti-skating weight wire support
- 7 Tonearm counterweight \* 7a Downforce scale
- 8 Anti-skating weight adjustment scale
- 9 Tonearm base

### Cartridge downforce adjustment (Pro-Ject Evolution tonearms)

Remove the transport lock (3) from the tonearm. Store it in the original packaging so they are available for any future transportation.

Pushing carefully, turn the counterweight (7) onto the rear end of the tonearm tube (2), so the downforce scale (7a) shows towards the front of the player. Lower the armlift and position the cartridge in the space between arm rest and platter. Carefully rotate the counterweight (7) until the armtube is balanced (floating level). The arm should return to the balanced position if it is moved up or down. Do not forget to remove the cartridge stylus guard if fitted.

Once the arm is correctly balanced, return it to the rest (3). Hold the counterweight (7) without moving it, and gently rotate the downforce scale ring (7a) until the zero is in line with the anti-skating prong (8). Check whether the arm is still balanced.

Rotate the counterweight counter-clockwise (seen from the front) to adjust the downforce according to the cartridge manufacturer's recommendations. One mark on the scale represents 1 mN (= 0.1g / 0.1 Pond) of downforce.

Tonearm Pro-Ject 12cc Evolution: The counterweights (7) supplied are suitable for cartridges weighing between 4-7g, 6-9g, 8-12g or 10-15g.

Adjust the downforce prior to installing the anti-skating weight.

### Adjusting the azimuth (Pro-Ject Evolution tonearms)

The cartridge stylus must be vertical in the record groove in order to trace the groove wall modulations correctly.

A small screw at the bearing end of the arm allows incorrect azimuth to be corrected if your stylus is not mounted exactly perpendicular to the cartridge body (which is often the case).

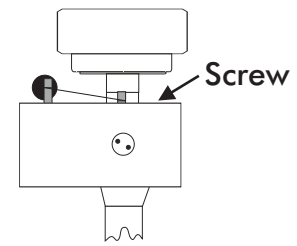

Slacken off the screw just enough to be able to revolve the arm tube without applying force. Note! Do not remove the screw completely!

With the aid of a good magnifying glass, adjust the stylus until it is vertical in the groove (i.e. perpendicular to the record's surface). Ideally this should correspond to the top surface of the cartridge body being parallel to the record surface, but in practice this is often not the case.

When you are satisfied that the stylus is vertical, retighten the screw carefully.



Under no circumstances should the arm tube be adjusted with the stylus still in the record groove! Irreparable damage may be caused to the cantilever suspension! The arm must be lifted to make each adjustment and lowered afterwards to check it.

### Anti-skating force adjustment (Pro-Ject Evolution tonearms)

The anti-skating force must be adjusted corresponding to the downforce as follows:

| <u>Downforce</u> | <u>Groove in the stub (15)</u>     |
|------------------|------------------------------------|
| 10-14mN          | 1 <sup>st</sup> from bearing rings |
| 15-19mN          | 2 <sup>nd</sup> " " "              |
| 20mN and bigger  | 3 <sup>rd</sup> " " "              |

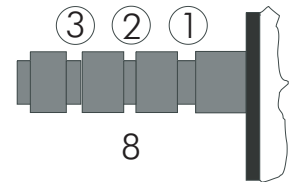

Hang the loop of the thread of the anti-skating weight in the groove of the anti-skating stub (15) corresponding to the downforce applied to your cartridge and hang the thread in the groove of the wire support (17).

### Adjusting the vertical tracking angle (VTA) (Pro-Ject Evolution tonearms)

Put a record on the platter. When the stylus is lowered into the record groove, the tube (2) of the tonearm should be parallel to the surface of the record.

If it is not parallel to the record surface, raise the stylus off the record, loosen both hexagon screws in the tonearm base (9) just enough to allow vertical movement of the arm pillar without force and slide the arm up or down until it is parallel.

Carefully retighten the hexagon screws without applying excessive force (which would deform the arm pillar) – finger-tight is quite sufficient.

### Technical specifications Pro-Ject 12cc Evolution

|                          |  |
|--------------------------|--|
| Tonearm                  | medium mass                                  |
| Supplied counterweights  | cartridge weight 4-7g, 6-9g, 8-12g or 10-15g |
| Downforce range          | 10-35mN                                      |
| Effective tonearm length | 12in (304.8mm)                               |
| Overhang                 | 13.2mm                                       |
| Tonearm cable length     | approx. 120cm                                |
| Weight                   | 271g (without counterweight)                 |

## Ortofon RS tonearms

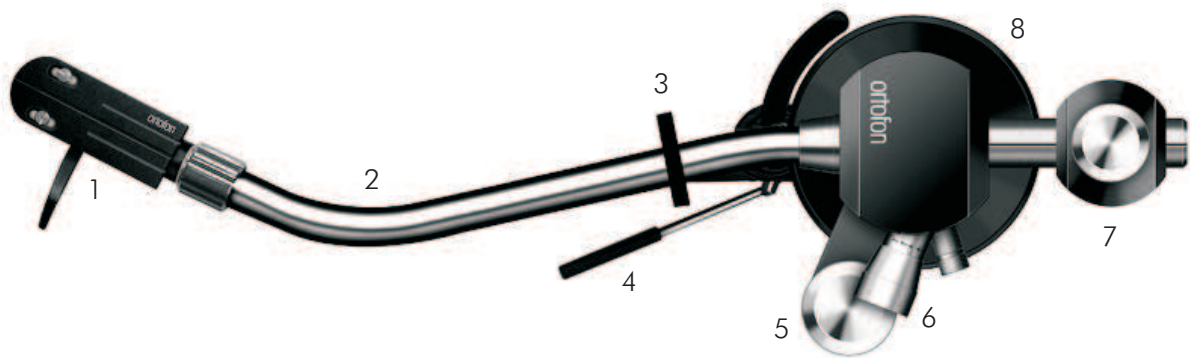

- 1 Detachable headshell with finger lift
- 2 Tonearm tube
- 3 Tonearm rest and removable transport lock
- 4 Tonearm lift lever
- 5 Anti-skating force adjustment knob
- 6 Downforce adjustment knob
- 7 Tonearm counterweight with securing screw\*
- 8 Tonearm base  
Stylus pressure gauge (not shown) \*

### Cartridge downforce adjustment (Ortofon RS-Tonearm)

Remove the transport lock (3) from the tonearm. Store it in the original packaging so they are available for any future transportation. Set the knob (5) to 0.

Place the counterweight (7) halfway along the counterweight support rod at rear of arm, ensuring that the counterweight's (7) securing screw uppermost. Lower the armlift and position the cartridge in the space between tonearm rest (3) and platter. Carefully move the counterweight (7) along the support rod, until the armtube (2) is balanced, i.e. floating level. The arm should return to the balanced position if it is moved up or down. Do not forget to remove the cartridge protection cap if fitted.

With the power off, and the platter static, place the supplied stylus pressure gauge onto the platter.

Carefully lower the armlift and position the tip of the stylus on the pressure gauge's measuring tongue. The downforce will be displayed digitally.

Adjust the downforce, using the knob (6), to the cartridge manufacturer's recommendations. This adjustment must be done with the tonearm resting on the tonearm rest (3). Finally secure the counterweight with the securing screw (7).

The counterweight (7) supplied is suitable for cartridges weighing between 18-40g.

### Anti-skating force adjustment (Ortofon RS and AS tonearms)

The anti-skating force must be adjusted corresponding to the downforce. Rotate the knob (5) to adjust the anti-skating force. One mark on the scale represents 5mN (= 0.5g /0.5 Pond) of downforce.

### Adjusting the vertical tracking angle (VTA) (Ortofon RS and AS tonearms)

Put a record on the platter. When the stylus is lowered into the record groove and the tonearm is not resting on the tonearm rest (3), the top surface of the cartridge body should be parallel to the surface of the record.



If it is not, loosen the hexagon screw in the tonearm base (8 RS tonearms or 7 AS tonearms) just enough to allow vertical movement of the arm pillar without force and slide the arm up or down until it is parallel.

Carefully retighten the hexagon screw without applying excessive force (which would deform the arm pillar) – finger-tight is quite sufficient.

#### Technical specifications Ortofon RS-212D and Ortofon RS-309D

|                          |   |
|--------------------------|---|
| Tonearm                  | medium mass   |
| Supplied counterweight   | cartridge weight 18-40g (including headshell)                   |
| Downforce range          | 0-50mN  |
| Effective tonearm length | RS-212D - 229mm/RS-309D - 326mm                                 |
| Overhang                 | 15mm  |
| Offset angle             | RS-212D - 22 deg. / RS-309D - 19 deg.                           |
| Tonearm cable length     | approx. 120cm   |
| Weight                   | RS-212D - 655g/RS-309D - 725g<br>(plus headshell and cartridge) |

#### Fitting and connecting the cartridge

All cartridges with half-inch mounting holes can be fitted. Leaving the stylus's protection cover in place, fit the cartridge to the headshell using the screws supplied with the cartridge by passing one screw through each slot in the headshell (1). Do not tighten the nuts at this stage.

Connect the tonearm wires to the cartridge pins as follows:

|       |                             |
|-------|-----------------------------|
| white | left channel positive (L+)  |
| red   | right channel positive (R+) |
| green | right channel return (R-)   |
| blue  | left channel return (L-)    |

The full sound quality of the turntable can only be achieved if the cartridge is correctly adjusted. Dedicated tools, such as PRO-JECT's alignment tool, will help you to accomplish this. If you are not well-acquainted with the adjustment of cartridges, you are advised to call upon the skills of your PRO-JECT dealer to undertake this task for you.



Please note: adjusting a cartridge and tonearm calls for the greatest care in order to avoid damaging the cartridge or tonearm bearings. Leave this work to your dealer if you are in any way unsure of the necessary steps and precautions to be taken.

## Service

Should you encounter a problem which you are not able to correct or identify despite the above information, please contact your dealer for further advice. Only when the problem cannot be resolved there should the unit be sent to the distributor in your country.

Guarantee repairs will only be effected if the unit is returned correctly packaged. For this reason we recommend keeping the original packaging.

Never return a record player without making sure that it is safely disassembled and correctly packaged in the original packaging. Please remove these parts and pack them separately: feet, counterweight, platter, cartridge and belt. Fit the cartridge protection cap. Insert the transport lock for the tonearm prior to carefully packaging the record player.

## Warranty



The manufacturer accepts no responsibility for damage caused by not adhering to these instructions for use and/or by transportation without the original packaging. Modification or change to any part of the product by unauthorised persons release the manufacturer from any liability over and above the lawful rights of the customer.

EAT EuroAudioTeam is a Registered Trademark of Jozefina Lichtenegger.

Copyright © 2010. All rights reserved.

The information was correct at the time of going to press. The manufacturer reserves the right to make changes to the technical specification without prior notice as deemed necessary to uphold the ongoing process of technical development.