

# McIntosh®

CR106 6-ZONE PREAMPLIFIER / AUDIO MATRIX



# McIntosh<sup>®</sup>

## SINCE 1949

Sound is not just the DNA of McIntosh, it is the heartbeat that resonates within every product we bring to life, connecting music lovers to the soul-stirring power of sound. Join us on a journey to elevate your sound experience.





## UNMATCHED MULTI-ROOM AUDIO CONTROL

The CR106 6-Zone Preamp delivers effortless control and unmatched flexibility, enabling you to simultaneously enjoy different music in different rooms of your home. Combining the features of a preamp and an audio matrix into one unit, it can be paired with our amplifiers and speakers specifically

designed for custom installations to create a multi-room, high-performance distributed audio system with exceptional sound quality that enhances every corner of your home.

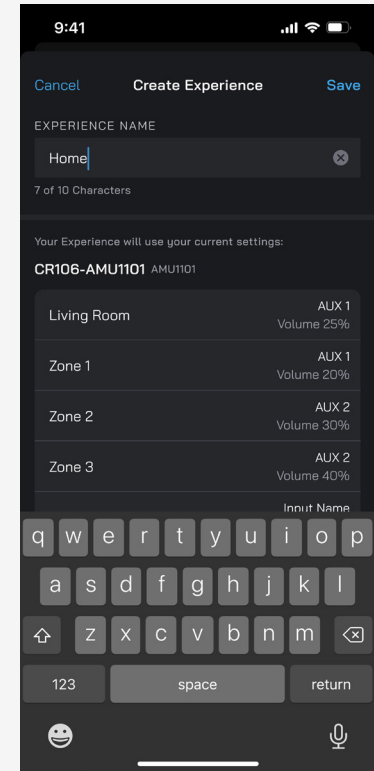
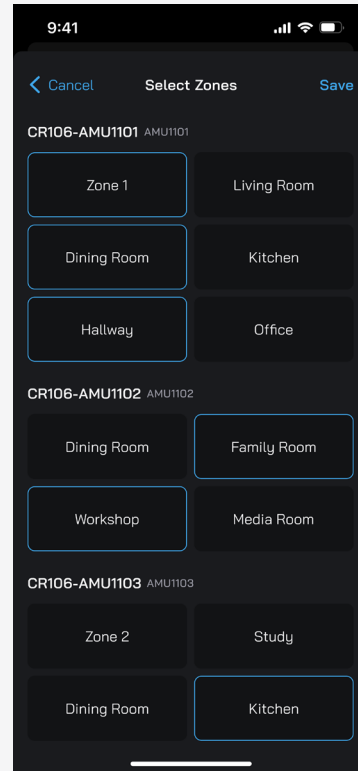
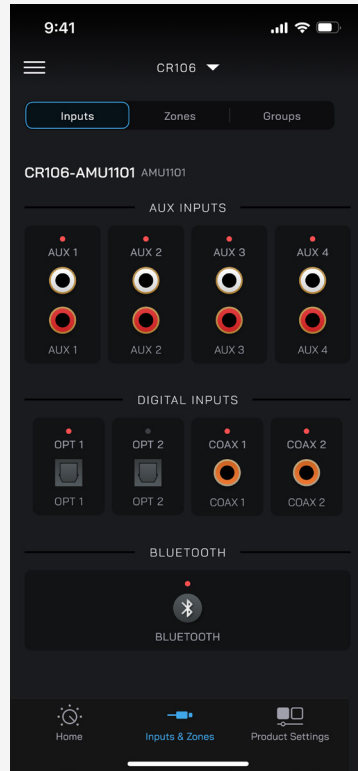
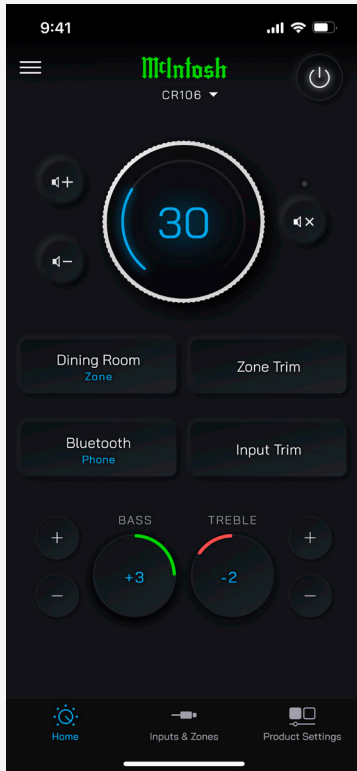

## EASY CONTROL AT YOUR FINGERTIPS

The CR106 is controlled by our free Connect app that is available for both Apple and Android devices, through a web interface, or by the intuitive front-panel knobs and buttons. Regardless of how you control the CR106, no complicated programming is required, so your system can be up and running quickly.

When using the Connect app, you can:

- Turn zones on and off.
- Name zones for easy identification.
- Select audio sources for individual zones.
- Adjust volume, bass, and treble for each zone.
- Configure subwoofer settings for zones with connected subwoofers.
- Group zones together.
- Select 1 of 6 optional EQ Voicings for each zone.



## EASY CONTROL AT YOUR FINGERTIPS (CON'T)

You can also create and customize Experiences using the Connect app or web interface. When you set up an Experience, the current input selection and volume levels for each zone are captured and saved.

These saved Experiences can be easily reapplied or activated anytime, offering quick and seamless audio control.



## FLEXIBLE CONNECTIVITY OPTIONS

Source components, such as CD players, music streamers, and tuners, can be connected via the 4 unbalanced analog inputs or the 4 digital inputs. For larger systems, up to five CR106 units can be linked together via Dante® network interface, creating up to 30 distinct two-channel audio zones. Adopted by hundreds of manufacturers in thousands of products, Dante replaces audio connections in larger multi-room systems with a computer network, effortlessly sending audio over your network to multiple locations.

You can also stream directly to the CR106 via Bluetooth, effectively turning your phone or tablet into a music source. The CR106 utilizes the high bitrate Advanced Audio Coding (AAC) standard; Qualcomm® aptX™ HD for hi res audio playback; and Qualcomm aptX Adaptive, a robust solution that delivers high resolution, uninterrupted audio over Bluetooth.

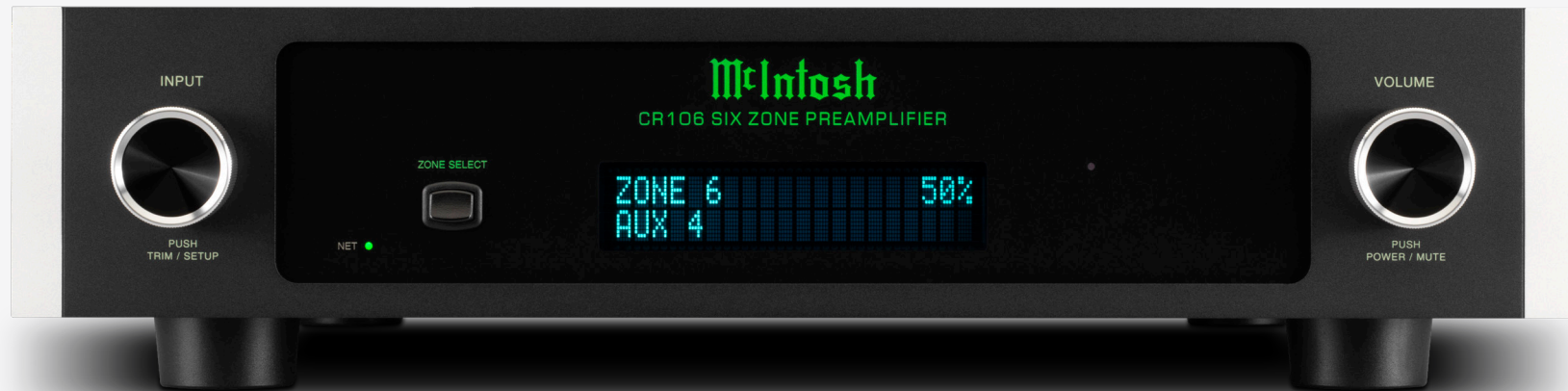

## FLEXIBLE CONNECTIVITY OPTIONS (CON'T)

Each zone has 2 sets of unbalanced outputs plus dedicated subwoofer outputs. Two outputs per zone allow for advanced configurations such as:

- Playing the same audio on 4 speakers and 2 subwoofers in one zone.
- Distributing the same audio across two zones simultaneously.

Your installer can further discuss these possibilities with you based on your specific needs.

Dedicated Power Control triggers allow synchronized power on/off functionality with connected McIntosh components, simplifying system management.

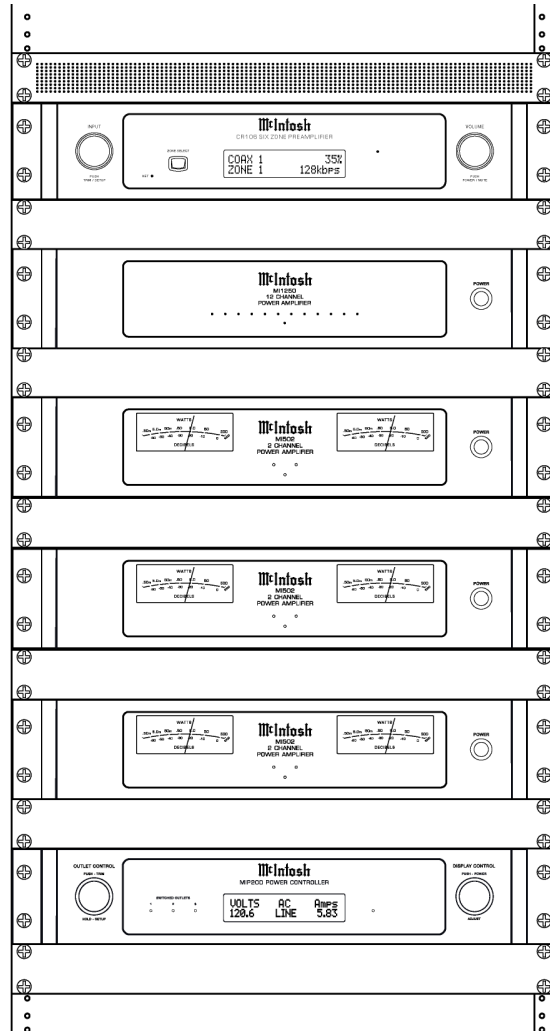

Diagram of a custom install multi-room distributed audio system featuring (from top to bottom): CR106, MI1250, MI502 (x3), and MIP200.

## STREAMLINED INTEGRATION INTO A DISTRIBUTED HOME AUDIO SYSTEM

The compact CR106 can easily be installed into a standard A/V equipment rack and requires just 2U of rack space (rack mounting brackets are included). Using unbalanced audio cables, its outputs can be connected to a custom install home audio amplifier, such as our:

- MI502 2-Channel Amplifier (500 watts per channel).
- MI254 4-Channel Amplifier (250 watts per channel).
- MI128 8-Channel Amplifier (120 watts per channel).
- MI1250 12-Channel Amplifier (50 watts per channel).

Pair these with our in-wall and in-ceiling speakers – like the WS500 In-Wall Speaker, WS300 In-Wall Speaker, or CS200 In-Ceiling Speaker – for a fully customized listening experience in every zone. Add the rack-mountable MIP200 Power Controller to protect your audio investment from unexpected electrical issues.

Transform your entire home into a haven of high-quality sound with the CR106 6-Zone Preamplifier. Contact your local integrator or dealer to learn more about adding the CR106 to your whole home distributed audio system.





## CR106 SPECS

### AUDIO SPECIFICATIONS

#### Frequency Response

±0.5dB from 20Hz-20kHz

#### Total Harmonic Distortion

High Level Inputs: 0.005% maximum from 20Hz to 20kHz

#### Signal To Noise Ratio - A Weighted

High Level: 96dB below rated Output

#### Rated Output Voltage

2.5V Unbalanced Outputs

#### Maximum Voltage Output

7V Unbalanced

#### Output Impedance

330 Ohms

#### Input Impedance

High Level: 50k Ohms Unbalanced

#### Sensitivity for Rated Output

High Level: 450mV Unbalanced

#### Maximum Input Signal

High Level: 4.5V Unbalanced

### CONNECTIVITY

#### Unbalanced Input: 4

#### Unbalanced Output: 6 Zones

(each zone has 2 sets of unbalanced outputs plus 2 dedicated subwoofer outputs)

#### Coaxial Input: 2

#### Optical Input: 2

#### USB Input: 1 (for service only)

#### Network LAN Connections: 2

### CONTROLS

#### Power Control Output: 6

#### RS232 Control Input: 1

#### Tone Controls: Bass and Treble

### WEIGHTS & DIMENSIONS

#### Unit Dimensions (W x H x D)

17-1/2" (44.5cm) (with mounting brackets)  
19" (48.3cm) x 4-3/8" (11.1cm)  
x 18-5/32" (46.1cm)

#### Unit Weight

15 pounds (6.8 kg)

#### Shipping Weight

37.5 pounds (17 kg)

Learn more:

Visit [mcintoshlabs.com](http://mcintoshlabs.com)

# McIntosh®



## About McIntosh

McIntosh Laboratory, Inc. is the premier American designer and manufacturer of high-fidelity audio equipment.

Founded in 1949, McIntosh products are handcrafted by experts passionate about creating an unmatched sonic experience. From its factory in Binghamton, New York to all corners of the world, the McIntosh blue meters have become a symbol of quality audio and continue to own the premiere position in home audio entertainment for discerning

listeners. Powering events like President Lyndon Johnson's inauguration speech, world-renowned concert systems like Woodstock, the Grateful Dead's Wall of Sound and Despacio, McIntosh has shaped some of the most important moments in music and culture. McIntosh gives music enthusiasts the power to create their ultimate sound experience.

## For the Consumer's Protection

In order to ensure the highest level of customer satisfaction, new McIntosh products may only be purchased from an Authorized McIntosh Dealer; and, with certain limited exceptions may only be purchased over-the-counter or delivered and installed by the Authorized McIntosh Dealer. McIntosh does not warrant, in any way, products that are purchased from anyone who is not an Authorized McIntosh Dealer, or that have had their serial numbers altered or defaced.

## Learn More

Visit [mcintoshlabs.com](http://mcintoshlabs.com)



DISCOVER CR106